

Objective and Subjective Evaluation of the Large Signal Loudspeaker Behaviour

Wolfgang Klippel, Klippel GmbH, Dresden, Germany, www.klippel.de

Abstract: The results of nonlinear and thermal loudspeaker modeling are the basis for simulating the transfer behaviour of loudspeakers in real time by using any electrical input signal (test stimulus, music). The model implemented in a DSP provides important state information (displacement, current, temperature) and allows a decomposition of the sound pressure output into the linear and nonlinear distortion components. This technique combines objective loudspeaker analysis with subjective auralization used as a new tool in loudspeaker design and basic research on the perception of loudspeaker distortion. Preliminary results of an interactive listening test currently performed on the website <http://www.klippel.de/aura/> are presented and the factors influencing the audibility of loudspeaker distortion are discussed.

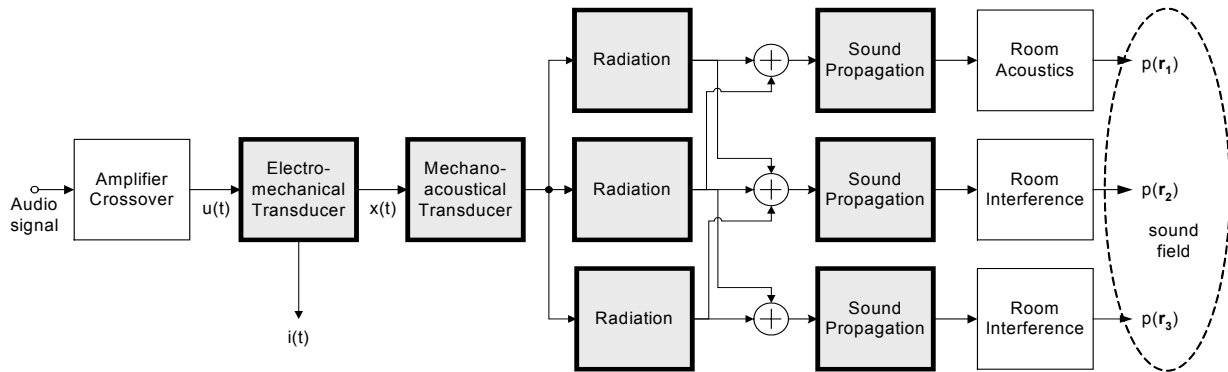

Fig. 1. Signal flow in a sound reproduction system

Introduction

For many applications small, light-weight and cost-effective electro-acoustical transducers are required which produce the required sound pressure output at high efficiency and acceptable signal distortion. Thus, targeting for “loud”speakers the large signal performance becomes more and more important. The nonlinear and thermal mechanisms are subject of research for many years and substantial progress has been made in modeling, measurement and nonlinear control to compensate for loudspeaker distortion actively. The theory and available practical tools show the relationship between the physical causes (large signal parameters of the loudspeaker) and the nonlinear symptoms (distortion, amplitude compression, instabilities, ...) generated by the transducer for any input (special test or ordinary audio signals). The new auralization technique combines subjective and objective evaluation of loudspeaker systems and answers the following questions:

- Under which condition does signal distortion become audible ?
- How strong is impact on subjectively perceived sound quality ?
- What are the physical causes for the distortion ?
- Which role plays the stimulus and the listening conditions ?
- How can the performance-cost ratio be improved ?
- Is the loudspeaker optimal for the particular application ?

These questions are important for defining product specification and to develop a loudspeaker meeting this targets.

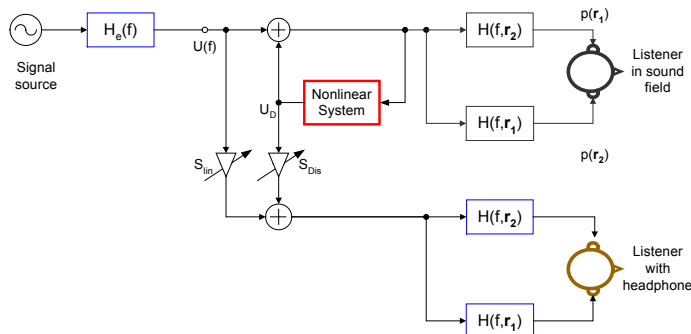

Fig. 2: Auralization technique illustrated by a signal flow chart between signal source and listener

Loudspeaker Modeling in real time

The Auralization techniques is based on the large signal model of the loudspeaker as illustrated in Fig. 1. The loudspeaker is a nonlinear and time-varying system having a single input (at the terminals) but multiple outputs (in the sound field). In the electro-mechanical transducer there are the dominant nonlinearities such as force factor $Bl(x)$ of the electro-dynamical motor, the compliance $C(x)$ of the suspension and the inductance $L(x)$ of the voice coil depending on the voice coil displacement x . In common woofers and other direct radiating transducers the cone vibration, radiation and propagation of the sound wave may be approximated by a linear system having a transfer function $H(f, r)$ depending on the listening point r in the sound field. For a fixed listener position the reproduction is modeled by the upper branch in Fig. 2. The first linear system $H_e(f)$ connected between the signal source and the terminals of the loudspeaker represents the amplifier, crossover and other electronics. Two linear systems $H(f, r_1)$ and $H(f, r_2)$ describe the signal path between loudspeaker terminals and left and right ear in the small signal domain where the loudspeaker behaves sufficiently linear. At high amplitudes a nonlinear system produces additional distortion U_D which are added to the undistorted input signal U . The nonlinear system corresponds with the nonlinear terms in the differential equation and depends on the linear, nonlinear and thermal parameters of the loudspeaker and instantaneous state variables (displacement current, velocity, temperature...). The nonlinear system is part of a feedback loop which causes nonlinear effects like higher-order distortion, amplitude compression and instabilities. Details about the modeling of nonlinear and thermal system are presented elsewhere [1-3].

The large signal model is implemented in a digital signal processor (DSP) and is able to process any input signal in real time and provides all state information of the loudspeaker. For example Fig. 3 show the peak and bottom value of voice coil displacement during the reproduction of three stimuli: Popular music (0 ...150 s), Drum signal (170 - 310 s) and a female singer (330 -520 s). Clearly the drum produces the highest and the singer the lowest excursion. Fig. 4 shows the input power dissipated on resistance R_e and the instantaneous temperature T_v of the voice coil. The drum signal caused the lowest heating of the coil due to high value of electrical input impedance and additional convection cooling of the coil.

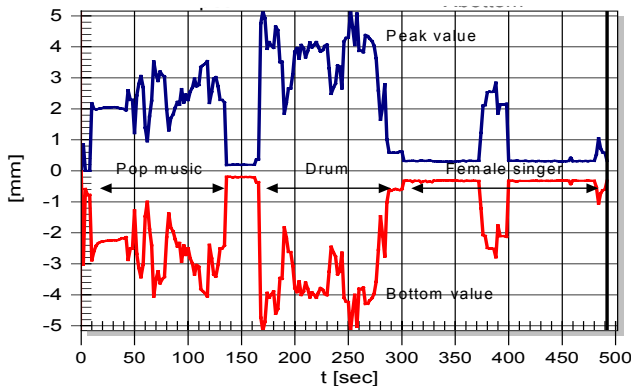

Fig. 3: Voice coil displacement during the reproduction of three stimuli

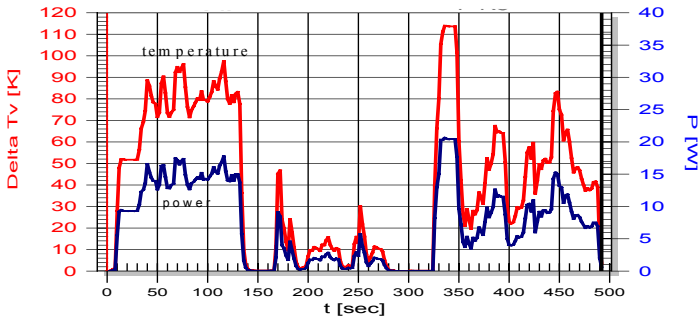

Fig. 4: Input power and voice coil temperature during the reproduction of three stimuli

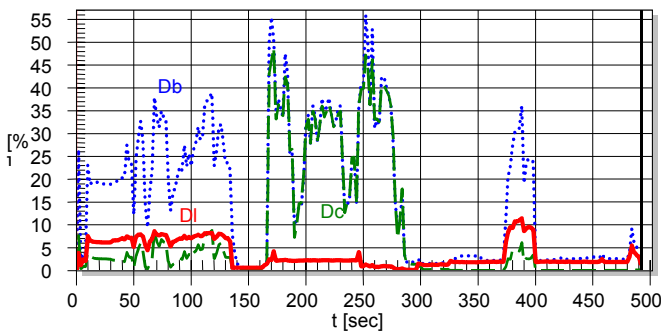

Fig. 5: Ratio of distortion components D_b , D_c , D_l generated by force factor $Bl(x)$, compliance $C(x)$ and inductance $L(x)$, respectively, during the reproduction of three stimuli

To real-time modeling allows also to assess the distortion in the output signal by filtering the nonlinear distortion U_D with linear system $H(f,r)$ and calculating the ratio or the peak value of filtered distortion and the total sound pressure output. This technique may also be applied to each term in the differential equation to assess the contribution of each separated nonlinearity. Fig. 5 shows the contribution of the force factor $Bl(x)$ as dotted line, compliance $C(x)$ as dashed line and inductance $L(x)$ as solid line. The spectral content of the stimulus has a major influence on the amount of the generated distortion. For example the drum signal produces highest values of force factor distortion D_b and compliance distortion D_c due to the high values of excursion. However, the popular music produces much higher inductance distortion D_l appearing as broad-band intermodulation in the pass band of the driver. The voice signal can be reproduced at much lower distortion because the voice coil displacement is much smaller.

Auralization

Simulating the loudspeaker behavior for an arbitrary stimulus in real time has two major advantages: First, the performance of a loudspeaker may be predicted on the basis of loudspeaker parameters. This is useful for the investigation of design choices without building a prototype.

The second advantage is to listen into the linear and nonlinear components of the radiated sound and to measure the safety margin which keep the nonlinear distortion below audibility. This is important for high-quality loudspeaker where nonlinear distortion should be below the hearing threshold under most listening conditions. Fig. 2 illustrates how this safety margin can be measured quantitatively. Both the linear component U and the nonlinear distortion U_D are weighted by the gain S_{lin} and S_{Dis} and the total signal is filtered by the transfer function $H(f,r_1)$ and $H(f,r_2)$ and supplied by a high-quality headphone to the left and right ear of the listener. This gain controller in the mixing console allows to attenuate or increase the distortion relatively to the linear signal. For example, setting $S_{lin}=1$ and $S_{Dis}=1$ generates an output which is identical with the output of the original loudspeaker. Switching off the linear signal $S_{lin}=0$ allows to study the properties of the pure nonlinear distortion. Using a configuration of $S_{lin}=1$ and $S_{Dis}=M$ allows to boost the distortion by factor S_{Dis} and to find the safety margin $M=S_{Dis}$ where the distortion become just audible.

Interactive Listening Tests

This auralization technique is the basis for systematic listening tests performed on loudspeakers to investigate the influence of the stimulus, the crossover, the enclosure type (vented or closed), the linear and nonlinear driver parameters and the acuity and training of the listener. Such a test is currently performed on the website www.klippel.de/aura/ using a double-blind technique based on the weighted up-down method [5]. Anybody is welcome to participate anonymously and may experience how various kinds of loudspeaker distortion sound like. The test is completely automated and the collected data are handled confidential. Participants will find a non-technical introduction and in-depth information as well. The judgments are investigated on-line and the participant may compare his results with the hearing capabilities of others.

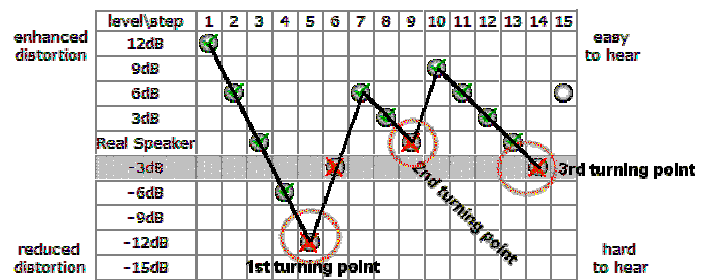

Fig. 6: On-line report of an interactive listening test

References

- [1] W. Klippel, "Distortion Analyzer – a New Tool for Assessing and Improving Electrodynamic Transducers," presented at the 108th Convention of the Audio Engineering Society, Paris, February 19-22, 2000, preprint 5109.
- [2] W. Klippel, "Prediction of Speaker Performance at High Amplitudes," presented at the 111th Convention of the Audio Engineering Society, New York, September, 21-24, 2001, preprint 5418, J. Audio Eng. Soc. Vol. 49. 12, 2001, December, p. 1216.
- [3] W. Klippel, "Nonlinear Modeling of the Heat Transfer in Loudspeakers," *J. Audio Eng. Society* **52**, erscheint Heft 1, 2004 January.
- [4] W. Klippel, "Speaker Auralization – Subjective Evaluation of Nonlinear Distortion," presented at the 110th Convention of the Audio Engineering Society, Amsterdam, May 12-15, 2001, preprint 5310, J. Audio Eng. Society, Vol. 49, No. 6, 2001 June, P. 526.
- [5] Kaernbach, C., "Simple adaptive testing with the weighted up-down method", *Perception & Psychoacoustics* 1991, 49(3), 227-229