

## New parameters for acoustic absorption

Cees Mulder<sup>1</sup>

<sup>1</sup> ing. Cees Mulder, Rotterdam, The Netherlands, Email: mail@ceesmulder.com

### Introduction

In the 1960's at the Philips Research laboratories a method was developed to vary the acoustics in a room using amplification of the diffuse sound. This was described by dr. N.V. Franssen [1]. In his paper and in following papers, the effect of the increase in reverberation time and energy density is described. This effect can be:

- 1) intentionally: when used for variable acoustics or acoustic corrections;
- 2) a parasite effect: when amplification is used for speech reinforcement, artificial acoustics (live surround sound), etc.

The subject described in this paper is not new, the way of presenting is rare. Apparently for many hard to understand, amplification in a room results in a reduction of the acoustic absorption in that room. This reduction is little when only a single or two channel system is being used. However, when multiple channels are used or high gain systems (due to decorrelation techniques), the reduction of absorption becomes noticeable. This paper focuses on this phenomenon as a parasite effect mainly.

### Amplification

A sound source producing  $W_0$  [W] generates a diffuse sound pressure  $p_0$  [Pa] in a room. When this sound pressure is picked-up by a microphone (random-incidence) and amplified, a sound power  $W_1$  is generated by the loudspeaker. This sound power  $W_1$  will produce a sound pressure  $p_1$ . So to say,  $p_0$  will be amplified, resulting into an increase of the total diffuse sound pressure. In Figure 1 below the scheme is given of the described amplification.

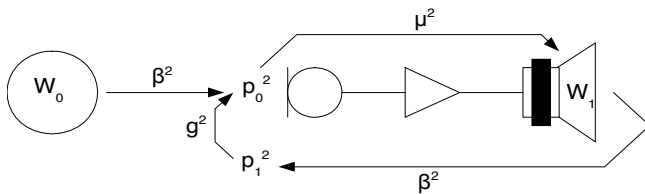

Figure 1: A single amplification channel

In this scheme the electrical transmission factor  $\mu^2$  can be described as in [2]:

$$\mu^2 = \frac{W_1}{p_0^2} \quad [\text{WPa}^{-2}] \quad (1)$$

The acoustical transmission factor  $\beta^2$  can be described as in [2]:

$$\beta^2 = \frac{p_0^2}{W_1} = \frac{4\rho c}{A} \quad [\text{Pa}^2\text{W}^{-1}] \quad (2)$$

The loop gain  $g^2$  of a single amplification channel in a room, of which the loudspeaker and microphone are located outside each others critical distance, can be described as follows :

$$g^2 = \frac{p_1^2}{p_0^2} = \mu^2\beta^2 \quad [-] \quad (3)$$

Using standard components without any decorrelation techniques, the loop gain  $g^2$  for a single amplification channel is limited to 0.02 (-17dB) [3]. This loop gain represents the amplification of the diffuse sound in a room by that channel. If for the situation an amplification channel is active in a room, the total diffuse sound pressure can be defined as  $p_{\text{act}}$ :

$$p_{\text{act}}^2 = p_0^2 + p_1^2 = p_0^2(1 + g^2) \quad [\text{Pa}^2] \quad (4)$$

When decorrelation techniques are applied in the amplification loop, a higher loop gain can be achieved. When more amplification channels are used in the same room as shown in Figure 2, the gain of the individual channels is added up.

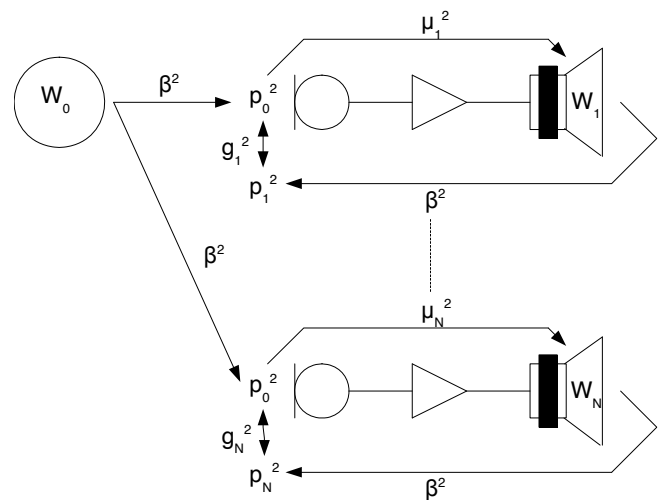

Figure 2: Multiple amplification channels

Note: an individual channel is an amplification channel coupled with other channels by the room only OR when it is electronically decorrelated with others. The total diffuse sound pressure in the room will now be:

$$p_{act}^2 = p_0^2 + p_1^2 + \dots + p_N^2 \quad [Pa^2] \quad (5)$$

$$= p_0^2(1 + g_1^2 + \dots + g_N^2)$$

If for the total acoustical amplification the total acoustic gain  $G_{ac}$  is defined,  $G_{ac}$  for  $N$  channels can mathematically be represented as follows:

$$G_{ac} = \sum_{i=1}^{i=N} g_i^2 \quad [-] \quad (6)$$

Note: the loop gain  $g_i^2$  of a channel is the loop gain with ALL amplification channels active.

## Effect of the amplification on the acoustic absorption

The diffuse sound pressure  $p$  in a room as function of the acoustic power  $W$  of a source and the acoustic absorption  $A$  present in that room is described as follows:

$$p_0^2 = 4\rho c W_0 \frac{1}{A} = \beta^2 W_0 \quad [Pa^2] \quad (7)$$

If the sound pressure is amplified by an electro acoustic gain  $G_{ac}$  under the condition the acoustic power of the source is kept constant, the following is valid for the sound pressure:

$$p_0^2(1 + G_{ac}) = 4\rho c W_0 \frac{1 + G_{ac}}{A} \quad [Pa^2] \quad (8)$$

$$= (1 + G_{ac})\beta^2 W_0$$

To describe a new situation for a room with electro acoustic amplification active, one can write the following:

$$p_{act}^2 = 4\rho c W_0 \frac{1}{A_{eff}} = \beta_{act}^2 W_0 \quad [Pa^2] \quad (9)$$

This means the acoustical transmission factor  $\beta^2$  increases when the electrical transmission factor  $\mu^2$  is being increased. This will result in a decrease of the effective absorption  $A_{eff}$ .

## New parameters for acoustic absorption: Architectural Absorption and Effective Absorption

The acoustic absorption commonly used is determined by the architectural acoustics, so one can name this the architectural absorption  $A_{arch}$ . The architectural absorption is defined as:

$$A_{arch} = \sum_{i=1}^{i=N} S_i \alpha_i \quad [m^2 \text{ o.w.}] \quad (10)$$

As the acoustic absorption changes in a room when amplification is present, the term "effective absorption" is being introduced, abbreviated as  $A_{eff}$  and defined as:

"The effective absorption is the architectural absorption corrected for the electro acoustical amplification of the diffuse sound."

For the effective absorption one then can write:

$$A_{eff} = \frac{A_{arch}}{1 + G_{ac}} \quad [m^2 \text{ o.w.}] \quad (11)$$

This means the effective absorption in a room decreases with respect to the architectural absorption in that room when electro acoustical amplification in that room is introduced or is being increased.

## Résumé

The acoustical absorption in a room is not only determined by the architectural acoustics, but also by the electro acoustical amplification present in that room, whether intentionally used or as parasite effect. This means the architectural acoustic absorption  $A_{arch}$ , now commonly used in Sabine's formula for the reverberation time and the formula for the diffuse sound pressure, should be replaced by the effective acoustic absorption  $A_{eff}$ .

## Recommendations to deal with the effect of decreasing absorption as consequence of amplification

The effects of decreasing absorption are commonly known:

- decreasing speech intelligibility;
- increasing noise;
- outrunning artificial acoustics.

When rooms are designed where the intention is to use systems that introduces significant amplification (as a parasite effect), one should deal with the effect of a decreasing effective absorption by:

- increasing the amount of architectural absorption;
- applying proper equalisation of the electro-acoustic system.

As the amplification can have a significant effect on the absorption it is proposed that:

- standards, e.g. IEC 12354-6, should be adapted for this phenomenon;
- programs for simulation model should have an option to take the effect into account;
- include the phenomenon into text books.

## Acknowledgement

The author wishes to thank ir. S.H. de Koning and ir. R.A. Metkemeijer for their constructive comments.

## References

- [1] N.V. Franssen, "Sur l'amplification des Champs Acoustiques", *Acustica* Vol. 20, 1968

- [2] S.H.de Koning, "Multiple Channel amplification of Reverberation", Proceedings of The Institute of Acoustics, Edinburgh 1982
- [3] Cees Mulder, "Variable Acoustics using Multiple Channel amplification of Reverberation (MCR)", International Congress on Acoustics, Rome 2001