

# Developments in the acoustic design of theatres with natural variable acoustics

Ir. M. Luykx, Ir. M. Vercammen, Ir. R. Metkemeijer

Peutz bv., Netherlands, email: [info@peutz.nl](mailto:info@peutz.nl)

## Introduction

Basically, there are two types of acoustics: the acoustics of the open air and the acoustics of closed spaces. The first type has minimal reflections, the sound that travels in a straight line between the speaker and the listener (direct sound) is dominant over the sound reflected by nearby objects. This type of acoustics is specifically suitable for transferring information, like speech, and to determine the direction of a sound source. It is the acoustics for the consonants. It has high definition.

In the second type, the direct sound is of little significance. Almost all energy reaches the listener in an indirect manner, by many reflections originating from the boundaries of the closed space. This type of acoustics is generally felt to be most suitable for musical sounds and vowels. It has low definition.

The open-air and the speech-theatre are characterised by short and/or very weak reverberation and the concert hall by long and/or strong reverberation; this makes a variation in acoustic properties necessary when a hall is used for both types of performances. One of the challenges designing halls with variable acoustics is not to compromise the strength of sound in the theatre mode. Specific acoustic requirements, as well as experiences and developments over the last 30 to 40 years with the design of theatres with natural variable acoustic will be illustrated, ending with an almost uncompromised theatre with variable acoustics in Zwolle (NL).

## Requirements on speech intelligibility

Speech intelligibility can be expressed by the true parameter  $AL_{cons}$  (Articulation Loss of Consonants). This is the percentage of wrongly understood consonants, measured using test persons. It is determined not only by the transmission channel, but also by speaker-listener effects (proficiency of the speaker, complexity of the message, familiarity with the content etc.). The speech intelligibility can be judged as good if the  $AL_{cons}$  value is below 10%, reasonable if between 10 and 15% and bad above 15%. Peutz defined a way to predict the  $AL_{cons}$  of the transmission channel based on distance, source directivity, room volume, reverberation time and the noise [5]. Other methods are to calculate the  $AL_{cons}$  based on the direct/reverberant ratio, reverberation time and the signal/noise ratio [7], or based on early and late sound and information theory [6,8]. Peutz stated that without direct sound  $AL_{cons}$  will be limited to  $9 * RT60$  [%], for situations without noise.

Based on statistical relations in the reverberation field without direct sound, it can be shown that a good intelligibility can be realized with  $RT60$  values of 0.8 to 0.9 s. In that case, at least 55-60% of the sound energy will arrive at the listener within 50 ms [10]. This part belongs to the early sound. It means that, provided sufficient sound energy is supplied by early reflections, there is no need for a direct sound to get a good intelligibility [11].

For theatres in which the spoken word is natural, acoustics must be created that is as loud as possible, because of the limitations in the sound power of the human voice. It can be deduced that the average gain ( $G$ ), defined according [9], should be at least  $G = +6$  dB. This is based on the following conditions: a minimal S/N ratio of 15-20 dB(A) as required for reasonable intelligibility [5], a sound power level of 70-75 dB(A) of an actor on stage, and a 3 dB loss of reverberant energy into the stage tower.

However, the acoustics should also have as much as possible direct (and early) sound and minimal (late) reverberation, because sound that is too reverberant may degrade speech intelligibility. To limit  $AL_{cons}$  values below 10%, the reverberation time should generally be limited to less than 1 second, preferably 0.8-0.9 s. Each room volume has its own optimal reverberation time, indicated by the green line in figure 1. In that case, provided there is sufficient loudness of the hall, the intelligibility of the reverberant (speech) sound will still be good, even at the furthest distances where direct sound is not relevant. According to the basic statistical laws of room acoustics, the best space for speech therefore is as small as possible, with reflective walls and ceiling and the only sound absorbing area being the audience. Additional absorption should be limited as much as possible, to maintain the loudness and the strength of early reflections. Although rigid criteria are hard to give, because a certain adaptation of the voice is well possible, the best theatres for classical plays are all smaller than 4,000- 5,000  $m^3$ , with a reverberation time of 1 second or less. This is indicated in figure 1, in which the above mentioned demands that have to be set for a theatre have been combined in one graph, resulting in the green area. For concert halls, the demands to be set are quite different ( $2 < RT < 2.3$ sec;  $4 < G < 5.5$  dB [9]). Those demands are also indicated in the figure 1.

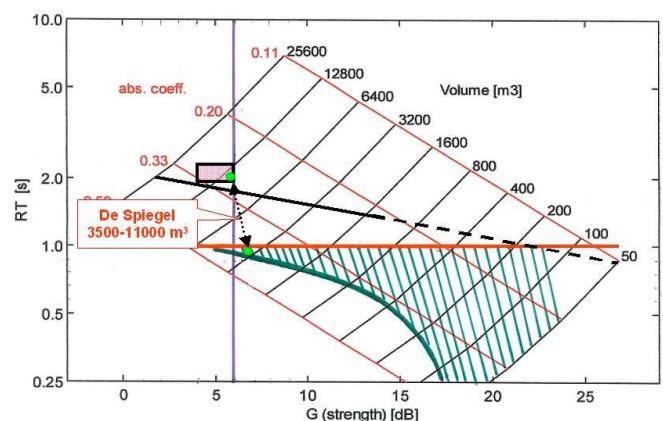

Figure 1: G-RT graph with optimal area for theatres (green area) and concert halls (small red rectangle).

## Developments in variable acoustics

In many places, theatre buildings have to be built that have to accommodate a wide variety of performances. If for reasons of building budget or running costs only one main

hall can be built, it is of course possible to create a compromise in its acoustics that will work more or less for all performances. Halls that are designed this way usually have a bad reputation regarding the acoustics (multi purpose is no purpose), when they have a size of more than 500 - 600 seats. For halls of smaller size the compromise is well possible, if properly designed.

In the 1970's variable acoustics started to be applied in this typical 'receiving' type of city theatre. With the acoustic requirements as mentioned above in mind, Peutz' acoustic design philosophy started from the hall size necessary for symphonic music. This was initially implemented in the *Stadsschouwburg Heerlen* (1962,  $V=4,200-5,000 \text{ m}^3$ ), but more clearly in the *Theater aan de Parade* (1976,  $V=4,500-5,000 \text{ m}^3$ ). A schematic plan and cross-section of this theatre is given in figures 2 and 3 (black lines), together with the characteristic example of an intimate theatre (Royal Theatre in The Hague,  $V=2,800 \text{ m}^3$ ) and concert hall (*Muziekcentrum Enschede*,  $V=16,000 \text{ m}^3$ ).

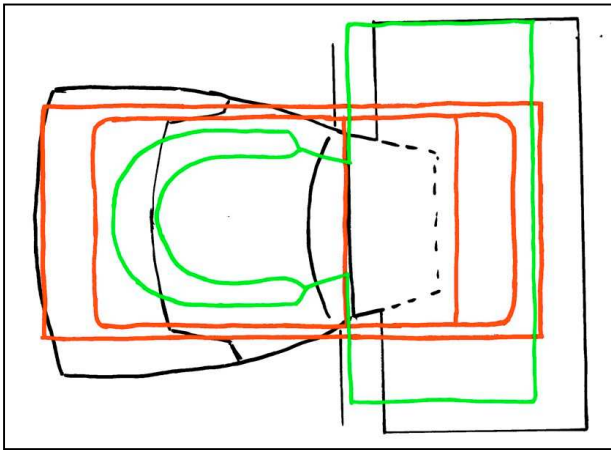

**Figure 2:** Schematic plan of *Theater aan de Parade* (1976,  $V=4,500-5,000 \text{ m}^3$ ) (black lines), combined with the plans of an intimate theatre (green) and a concert hall.

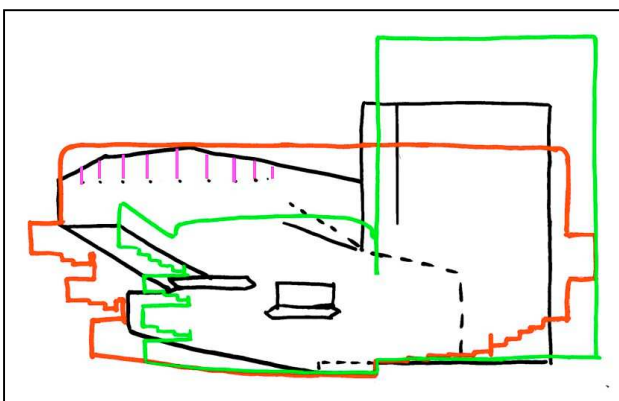
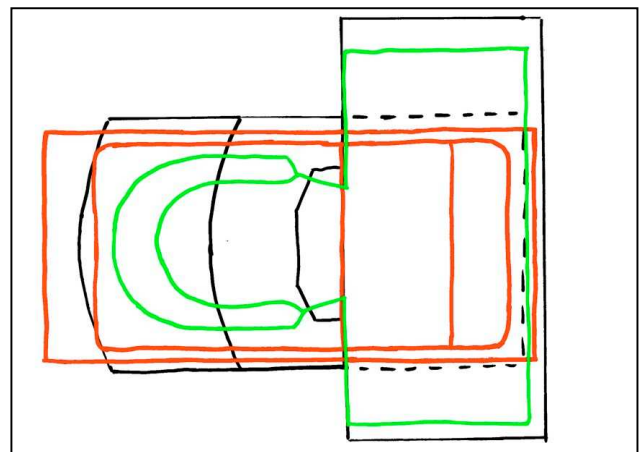

**Figure 3:** Schematic cross-section of *Theater aan de Parade* (1976,  $V=4,500-5,000 \text{ m}^3$ ) (black lines), combined with the cross-sections of an intimate theatre (green) and a concert hall (red).

This theatre was designed with a relatively large volume and stage opening. The stage was equipped with a movable orchestra shell. This basis would give a moderately long reverberation time of 1.5 - 1.7 s. In order to adapt the hall for classical plays, the stage opening can be reduced by movable

false prosceniums. A large amount of vertical curtains can be unrolled from the ceiling to add absorption, in order to shorten the reverberation time. The effective acoustic volume is reduced at the same time. On the other hand, a hall is created with a strongly sound absorbing ceiling; this is a clear concession to optimal conditions for natural speech.

This concept of a hall with variable acoustics was further developed in *De Lawei* in Drachten (1988), and the *Theater aan het Vrijthof* in Maastricht (1991), the *Stadstheater Zoetermeer* (1992) and in the *Zaantheater* (1998). A schematic plan and cross-section of the theatre *De Lawei* in Drachten are presented in figures 4 and 5 (black lines), together with the previous example of an intimate theatre (in The Hague) and concert hall. The basic shape of these halls is a rectangular box with sufficient volume for symphonic use. They have a stage opening of approximately 20 meters wide and 11-13 m high, a single main balcony and a gross height of 16-18 metres (to be reduced by vertical curtains to 12-13 metres, total area of curtains 1,000  $\text{m}^2$  or more). The size of the orchestra shell is usually  $20 \times 14 \times 12 \text{ m}$  (d x w x h). The total room volume of these halls including orchestra shell is 9,000 - 11,000  $\text{m}^3$ . The (effective) volume in the theatre mode is approximately 5,000 - 6,000  $\text{m}^3$ . The reverberation time varies usually from 0.9 - 1.1 seconds in theatre mode, to 1.6 - 2.0 seconds in concert mode. This concept for variable acoustics works technically quite well.



**Figure 4:** Schematic plan of *Theater de Lawei* in Drachten (1976,  $V=4,800-11,000 \text{ m}^3$ ) (black lines), combined with the plans of an intimate theatre (green) and a concert hall.

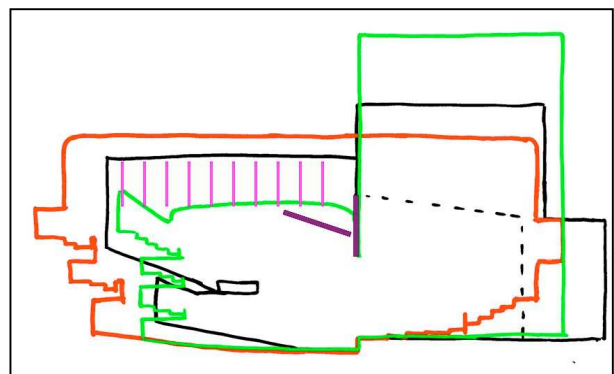

**Figure 5:** Schematic cross-section of *Theater de Lawei* in Drachten (1976,  $V=4,800-11,000 \text{ m}^3$ ) (black lines), combined with the cross-sections of an intimate theatre (green) and a concert hall.

The only drawbacks are the extra sound absorption in the theatre mode, (where the strength of sound is lost) and a slightly less full, reverberant sound (due to the absorption of the chairs resulting from the good sight lines). Another disadvantage may be a certain loss in architectural freedom for the hall design, and that these halls are not really intimate.

### Next and final step in development

A next step in the development should therefore be to create a more effective volume variation, so that in the theatre mode, less or no increase in total sound absorption would be necessary. A step in this direction was made in the main hall of *De Harmonie* in Leeuwarden (1994) where approximately 60 % of the ceiling consists of large panels that can be lowered to vary the hall's height. On top of these elements and exactly in the same position under the roof of the hall, strongly absorbing material is applied, to make the space above the lowered ceiling as 'dead' as possible, so the 40 % area between the ceiling panels acts almost as 100 % absorptive area. In the concert mode, with the ceiling in its highest position, all this absorption is disconnected from the hall by closing it off. The advantage of this solution is that less energy is lost in the theatre mode, but the range in reverberation time is somewhat reduced.

The final step in this development was made in the theatre *De Spiegel* in Zwolle (NL, 2006). Based on the experience with good and intimate theatres for natural speech like The Royal Theatre in The Hague [1], this hall was designed as compact as possible. Contrary to the previous halls, in this case the start of the design was not the concert hall, but a small theatre with 850 seats and a volume of approximately 3,500 m<sup>3</sup>. It has 2 horseshoe shaped balconies, an average room depth of 18m and a maximum room width of 20m. Although the amount of seats (850) is higher than in the Royal Theatre in The Hague (675), theatre *De Spiegel* can still be considered an intimate theatre, as is illustrated in figure 6 and 7. In these figures, the plan and a cross-section of *De Spiegel* are drawn, together with the schematic plan and cross-section of the Royal Theatre in The Hague.

The ceiling in the theatre mode is as low as possible: approximately 12 metres, mainly determined by the position

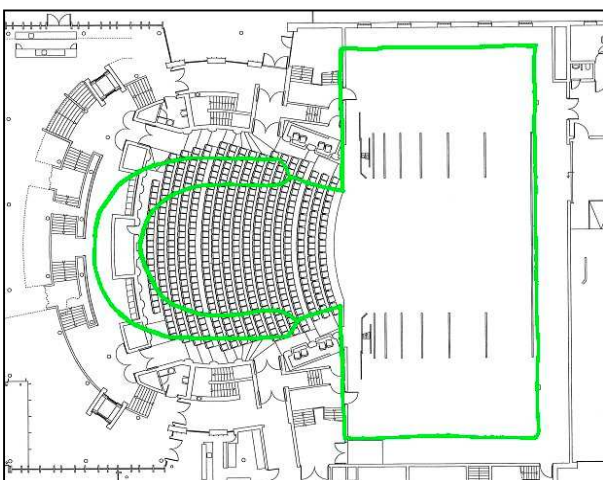

**Figure 6:** Plan (ground floor) of theatre *De Spiegel* in Zwolle in theatre mode, with schematic lines (green) of the plan of the Royal Theatre in The Hague.

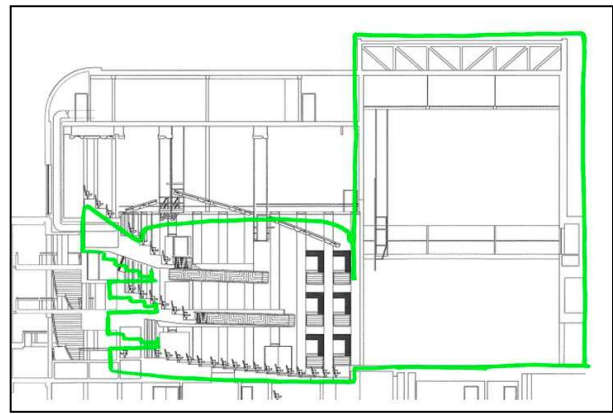

**Figure 7:** Cross-section of theatre *De Spiegel* in Zwolle in theatre mode, with schematic lines (green) of the cross-section of the Royal Theatre in The Hague.

of the light bridges. The width of the stage opening can be adapted from 18 to 14m using turnable side-boxes, that also adapt the width of the hall to a smaller stage opening. In figure 8 and 9 the effective acoustical volume of the theatre in the theatre mode is illustrated (red area).

To create the hall for symphonic music, the ceiling can be set at 20 metres height, revealing an extra volume of over 4,000 m<sup>3</sup> which is added to the hall as a kind of gallery with

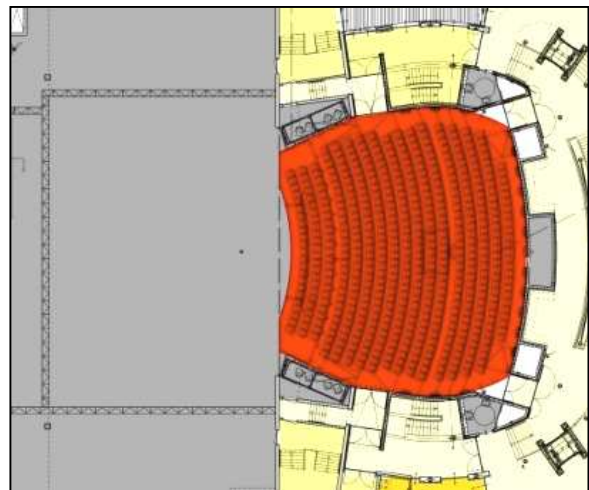

**Figure 8:** Plan (ground floor) of theatre *De Spiegel* (2006, V=3,800-11,000 m<sup>3</sup>) in theatre mode. The red area indicates the acoustical room volume.

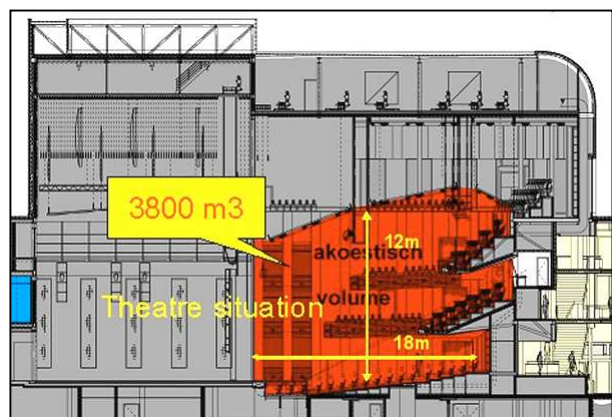

**Figure 9:** Cross-section of theatre *De Spiegel* in Zwolle (2006, V=3,800-11,000 m<sup>3</sup>) in theatre mode. The red area indicates the acoustical room volume (V=3,800 m<sup>3</sup>).



an additional 150 seats. This added volume using a gallery was based on experiences from the refurbishment of the Royal Albert Hall as consulted by Peutz (1999-2002), where it was discovered that the gallery and its reverberance played an important role in the reverberation of the room. In figure 10 and 11 a plan of the gallery level and a cross-section of the hall in the concert mode are presented, together with several dimensions and the acoustic volumes (indicated by the red area). The increase of the acoustic volume can be deduced by comparing the red area surfaces with those of figure 8 and 9.

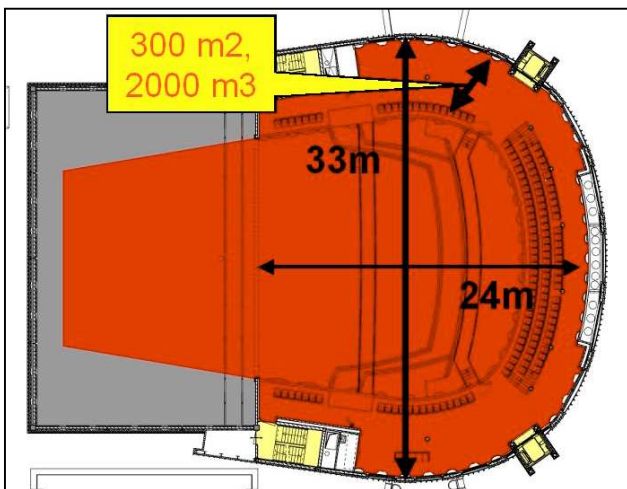

**Figure 10:** Plan (gallery-level) of theatre *De Spiegel* (2006,  $V=3,800-11,000\text{ m}^3$ ) in concert mode. The red area indicates the acoustic volume.

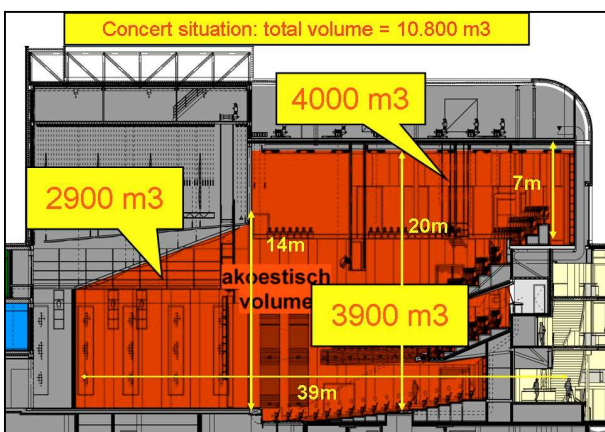

**Figure 11:** Cross-section of theatre *De Spiegel* in Zwolle NL (2006,  $V=3,800-11,000\text{ m}^3$ ) in concert mode. The red area indicates the acoustic volume.

Including the installation of an orchestra shell, a total volume of  $11,000\text{ m}^3$  is created in this theatre in Zwolle, which is a factor three over the theatre mode. This concept was extensively tested in the design phase using scale model research [3]. Measurement results reveal its interesting properties, that fulfil the goals set: The reverberation time varies from just under 1 second to 2 seconds without compromise to the strength of the sound in the theatre mode. The G-values of the hall are +6 dB in concert mode, and +7 dB in the theatre mode, as indicated in figure 1. Average

clarity  $C_{80}(3)$  values range from 0 dB for concert use to +7 dB for theatre.

The wide variation of acoustic properties of this theatre is also indicated in the G-RT graph of figure 1, in which it can be seen that for both uses the characteristics of the hall with respect to V, RT and G are within the optimum ranges for G and RT.

The design process and conception of this new theatre in Zwolle are described in English in the book "*De Spiegel: Theatre architecture as a mirror of experience*"[4]. The acoustics realized in this theatre are described in several previous papers [1,2,3]. Since the opening of the theatre, this new concept for variable acoustics has inspired others for similar projects abroad.

We feel that the development towards the creation of multi purpose theatres with acceptable acoustics for a wide range of performances, which began in the nineteen seventies, has reached a (temporary) final point in Zwolle (2006). These days, virtually no concessions are made to the acoustical quality for natural speech and the quality for symphonic music. In the past it was often said that a multi purpose theatre was a no purpose theatre. But with sound variable acoustics it has proven to be possible to create multi purpose theatres, without compromises.

## References

- [1] M. Luykx, M. Vercammen, R. Metkemeijer, Acoustic design of theatres for natural speech and/or variable acoustics. Proceedings of the Institute of Acoustics **30**. Pt.3 (2008)
- [2] M. Luykx, R. Metkemeijer, M. Vercammen. Variable acoustics of theatre De Spiegel in Zwolle (NL): Proceedings of the I.S.R.A, Sevilla, 2007
- [3] M. Luykx, R. Metkemeijer, The new theatre in Zwolle (NL): Acoustical design and scale model study. Proceedings of the Institute of Acoustics **28**. Pt.2 (2006).
- [4] Hilde de Haan, *De Spiegel, theatre architecture as a mirror of experience.*, Architectura & natura Press, Amsterdam 2007, ISBN 978 90 7686 353 5.
- [5] V.M.A. Peutz, Designing sound systems for speech intelligibility, AES Convention 1974
- [6] Speech information and speech intelligibility, V.M.A. Peutz, AES Convention 1988.
- [7] J.v.d.Werff e.a, What you specify is what you get (part 1), 114<sup>th</sup> AES convention 2003.
- [8] J.v.d.Werff e.a., What you specify is what you get (part 2), 114<sup>th</sup> AES convention 2003.
- [9] L. Beranek, Concert Halls and opera houses, Music, Acoustics and Architecture. 2<sup>nd</sup> Edition, 2004, Springer-Verlag New York Inc.
- [10] R.A. Metkemeijer, Speech-intelligibility and room-size, journal of the NAG 81 (1986).