

Design and implementation of a listening room in accordance with the ITU-R BS 1116-1 standard

Andrea Sereinig¹, Markus Künstner¹, Maria Fellner², Franz Graf², Harald Rainer², Andreas Reiter³

¹ Graz University of Technology, A-8010 Graz

² JOANNEUM RESEARCH Forschungsgesellschaft mbH, DIGITAL – Institute for Information and Communication Technologies, A-8010 Graz, E-Mail: maria.fellner@joanneum.at

³ Reiter Viollet corporate architecture, A-8010 Graz

Introduction

As part of the project “Advanced Audio Processing (AAP)” [1] the work package ‘Expert listening panel for sound quality evaluation’ focuses on the problems and challenges of assessing professional audio applications and equipment. While a lot of test centers exist for objective measurements, the lack of facilities for the realization of subjective listening tests makes it difficult to obtain repeatable and reproducible results. The fields of application and the products being tested in the facility which is subject to this work are:

- Sound quality of microphones for studio and automotive applications; from in-ear headphones to professional studio headphones, etc.
- Spatial attributes of sound fields
- Speech quality (e.g. of voice recorders during playback)
- Data representation through sound (e.g. assessment of sonified signals)

The basic problem with listening tests in general is the complex interaction between stimulus and the resulting sensation. In most cases, the scientific interpretation of such stimuli is only feasible by interrogating a bigger group of listeners. If the obtained results are to be statistically representative for the entirety of all possible listeners, the group of test listeners must be chosen carefully. For this purpose, a group of professional listeners - the so-called listening panel - is needed in order to yield consistent results. Moreover, standardized listening test interrogation structures need to be maintained to achieve a repeatable assessment procedure. The task of selecting and training a group of professional listeners and the challenge of implementing a standardized assessment procedure has been distributed among the research partners and is not subject to this work.

It would be desirable, especially for the industry, to create a facility that is as neutral as possible, which should then receive tasks from the industry. As a final goal, it would be desirable to obtain a test location that is able to deliver some kind of certification similar to those of Dolby or THX at the moment.

Design and Simulation

In the design stage a listening room was specified and built which fulfils one of the current standards for the assessment of audio systems. The aim of this work was to determine the inner life of the target room to meet the requirements of the

chosen standard. First, former similar listening room projects were searched for. Subsequently, the major currently existing standards for the assessment of audio systems and sound material were quoted and compared, thereupon the most suitable was chosen. Our choice was the ITU-R BS 1116-1 standard [2] because of the small floor area of the existing target room at the JOANNEUM RESEARCH site in Graz/Austria (see fig. 1).

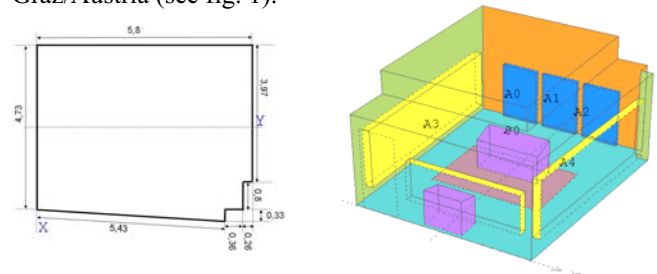

Figure 1: Ground plan of the target room at JOANNEUM RESEARCH (left), room model with absorbers and furniture implemented in CATT Acoustic® (right)

To be able to simulate the room’s acoustics, its geometry was implemented in the commercially available software CATT Acoustic®. The calibration of the simulation was then accomplished with values obtained by a thorough measurement of the empty target room by employing the commercially available software WinMLS. Afterwards, the optimization process could be started. The chosen standard, however, primarily defines the reverberation time of a listening room. Thus the virtual room was equipped in order to attenuate the sound field in accordance with the standard’s requirements.

As a result, two solutions for a listening room are presented. One variation was implemented using the existent step in the ceiling. A second variation omits the step.

After shaping the room the optimization process could be started. For this, acoustic material from several companies was tried out in the simulation until the best combination, which yielded the desired acoustic values, was found. The task was more difficult than presumed, since a large variety of different absorbers exist. An advantage to the work was that the sound field needed only to be attenuated according to the ITU standard’s recommendation. A list of the material was given along with a detailed plan of the placement of the absorbers, for each room variation a different fixture. The results for both approaches of the room’s geometry were both surprisingly good. The reverberation time results were all within the limits recommended by the standard, except

for minor variances which could be neglected. Furthermore, the given budget limit was kept. Finally, it can be said that the results obtained by the simulation are very satisfactory (fig. 2, red line). In addition, a list of the required acoustic material, furniture and sound system is given along with exact planning on how and where to place them (fig. 1 bottom).

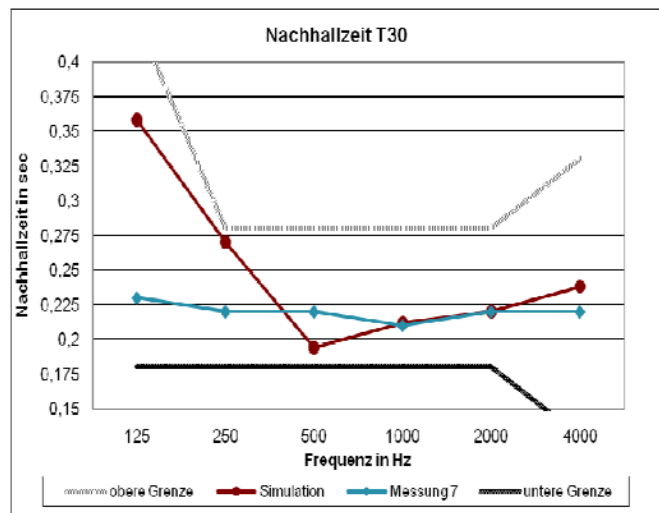

Figure 2: Reverberation time T30 of the equipped listening room (red – simulation, blue – measurement)

Measurement

During the whole construction period acoustic measurements were done for documentation purposes. For these measurements the software WinMLS was used with 4 microphone and 2 source positions. Figure 3 shows the final listening room with acoustic absorbers, equipment and furniture. The loudspeakers were positioned according to the ITU standard’s recommendation with little variation for the side speakers (see fig. 4).



Figure 3: Listening room with acoustic absorbers, equipment and furniture

Conclusions

The simulated room model is in very good accordance with the real room, which shows the value of the simulation technique, as well as the ITU standard. There was only one

variation between the virtual and the real room: in the simulation there were three low-frequency absorbers positioned in front of the windows, whereas the measurements showed that these were not needed in the real room.

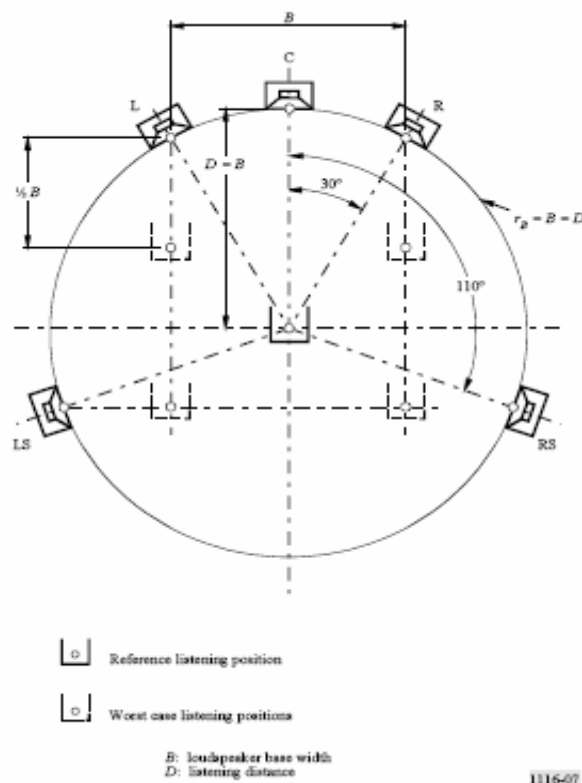

Figure 4: Positioning of the loudspeakers according to the ITU standard’s recommendation

Acknowledgements

This project is funded by the Austrian Research Promotion Agency (FFG), the Styrian Government and the Styrian Business Promotion Agency (SFG) under the COMET programme.

The work package “Expert listening panel for sound quality evaluation” was done in cooperation with AKG Acoustics GmbH, the Institute of Electronic Music and Acoustics at the University of Music and Performing Arts Graz and the Institute of Signal Processing and Speech Communication at Graz University of Technology.

References

- [1] <http://www.comet-aap.at/>, 22 March 2011.
- [2] ITU-R: “Recommendation BS 1116-1, Methods for the Subjective Assessment of Small Impairments in Audio Systems Including Multichannel Sound Systems”. International Telecommunication Union Radiocommunication Assembly, 1997.