

Low-Frequency Broadband Vibration Damping Using the Nonlinear Damper with Metamaterial Properties

Sifa Gul Demiryurek¹, Anton Krynkina¹

¹ *University of Sheffield, Engineering Faculty, Mechanical Engineering Department, PhD student, sgdemiryurek1@sheffield.ac.uk*

¹ *University of Sheffield, Engineering Faculty, Mechanical Engineering Department, Lecturer, a.krynkina@sheffield.ac.uk*

Abstract

Particle dampers are structural vibration treating options that have been used in applications for more than the last decade. Kinetic energy and momentum changes in the contact interactions are the main reasons for energy dissipation. Effectivity of the particle dampers depends on many parameters; the frequency range and amplitude of the excitation are examples of these parameters, making the particle damping application nonlinear. This research is based on the particle damping application within an array using metamaterial properties to broaden the low-frequency range vibration dissipation. In this case, metamaterials are subwavelength structures that offer superior vibro-acoustic properties. The enclosure cavity of the particle dampers is designed to illustrate local resonance properties within the selected mode frequencies of the main structure that is under excitation impact. Equivalent structure continuum modelling of the particle dampers has been accomplished through DEM and the analytical methodology using granular structure contact properties. The metamaterial unit cell modelling is based on the Bloch-Floquet Theory using FEM. Also, the finite structure modelling of the nonlinear damper with metamaterial application is modelled in FEM. Annotations related to the nonlinearity of the particle dampers and vibro-acoustic dispersion relations in metamaterial application are shown in the paper using experimental validations.

Introduction

Particle dampers are vibration amplitude reduction techniques in the passive damping treatments. These dampers are designed with an enclosure cavity which has granular structure inside. The damper geometry might be in variety of shapes depending on the application ranges and areas. In addition to that, the granular structures might be in any shape, as well. However, spherical particles are the most preferred ones for the granular structure shape. These structures are produced in ceramic, metals, or viscoelastic materials.

As it has been mentioned, the granular structures are placed in the cavities in order to prepare a particle damper. Particle or particles might be placed in one or several cavities. These cavities can be designed as an additional structure, or it can be placed/mounted on the same structure [1].

Particle dampers are one of the most useful passive damping options since the maintenance requirement is less than other

passive damping options. Also, the particle dampers are quite economic and wide band applications. For instance, liquid dampers and friction dampers are type of passive damper types. These dampers are useful damping methods in order to reduce the excitation impacts from the structures. However, both of the damper types are sensitive to the temperature levels. One of them faces with the leakage issues in the higher temperature levels. The other one, also, reduces the effectivity in the increased temperature levels since their material properties and wear problem increase in the raised temperature levels. However, particle dampers are tolerable applications to the temperature levels.

Granular structures in the cavity absorb the energy of the excitation through the enclosed cavity. Particles collide with each other and with the cavity walls. Energy is dissipated according to these collisions that are elastic and inelastic collisions in general. These collisions change the kinetic energy level of the particles. Thus, the momentum of the particles are changes, as well. Excitation amplitude is the decisive property on the collisions; the particles move, slip or stick according to the excitation amplitude. Therefore, the particle dampers are amplitude dependent applications which is also known as nonlinear dampers [2].

There are several application areas that particle dampers are placed to control the structural vibration: for instance, aerostructures, machinery and civil engineering. These applications are specifically designed and mode shape of frequency band focused applications [3].

In this research study, nonlinear dampers are aimed to be used in an array or placement in order to reduce the excitation impact and widen the tuned low frequency ranges. The study aims that this periodic arrangement of the particle dampers using locally resonant properties of the damper increases the nondispersive properties on the main structure which is under sinusoidal excitation. In order to succeed the aimed study, locally resonant damper cavity has been modelled and experimentally studied on a fixed-fixed conditioned beam with steel and DELRIN POM particles with a decided amount of filling ratio. Equivalent continuum structure material properties have been calculated using discrete element-based analysis data and applied to the finite element-based unit cell modelling. According to the studies, periodically arranged nonlinear dampers have been proven with widened low frequency bandgaps.

Methodology

This study has been modelled to conduct collective research in periodically arranged nonlinear dampers. Since, the resonating structures have shown distinctive dispersive properties when they are used in periodic arrangement, the damper casing has been modelled to show resonant properties at the selected frequency range. The particle damper-based study has been developed using experimental modelling of damper casing-beam-shaker and numerical validation of the experimental studies using DEM (Discrete Element Method) and FEM (Finite Element Method).

Particles are made of steel and DELRIN POM within size of 1/16 inches (= 0.0625 mm) of diameters with several filling ratios. Since the size of the particles are in the same sizes, this study is a good opportunity to compare the viscoelastic-based particles and metal-based particles in their damping properties. The data which were recorded through the bare beam-shaker tests were used for the excitation amplitude numerical modelling of the particle damper using DEM in the software of EDEM (Figure 1). Granular structures have been modelled using each particle material properties and Hertz-Mindlin Contact Theory has been used for modelling the contact between the particle-particle collisions and the particle-wall collisions. Since the particle materials are divided as metals and viscoelastic, the contact definitions are varied according to the particle materials.

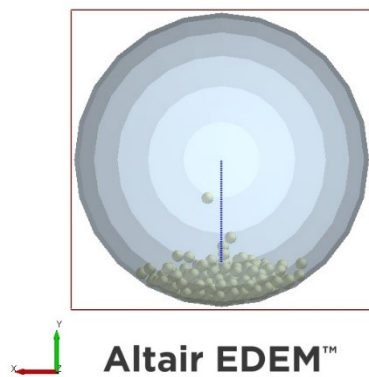

Figure 1: Discrete Element Method modelling of the granular structures

The data were taken from the DEM-based analysis in order to develop an isotropic structure material property corresponding the granular structure part of the particle damper, which method has been introduced in [4]. These isotropic material properties were used in the FEM-based continuum structure as a particle damper. The resonating damper cavity and additional attachment of the granular structures were placed on the beam for a finite structure modelling aiming to get frequency response of the main structure when damper attachment is placed (Figure 2). In addition to this, the unit cell modelling was developed using Bloch-Floquet Modelling while turning the whole structure to the spring-mass system with the periodicity conditions applied through the main axis of the beam (Figure 3). The spring-mass system was prepared according to the resonating structure properties of the damper casing and the isotropic structure modelling of the granular structures.

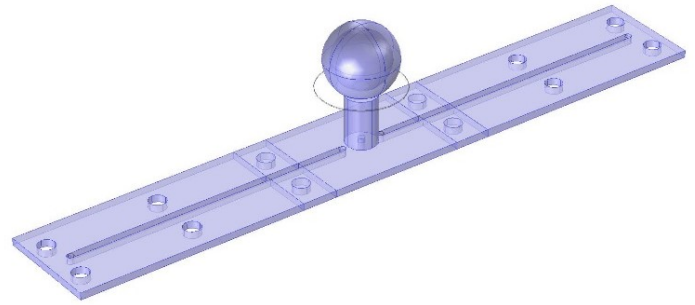

Figure 2: Finite Element Method modelling of the damper-beam system (finite structure)

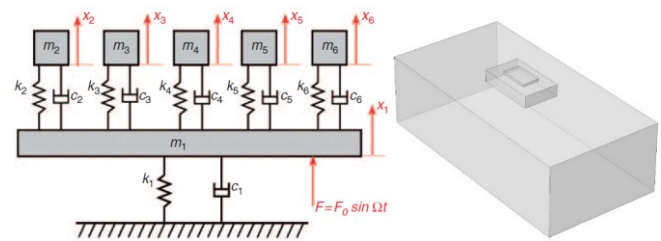

Figure 3: Finite Element Method modelling of the whole structure as an infinite structure using unit cell modelling

Results

According to the experimental studies conducted using the particle dampers, it has been understood and validated that the particle dampers are nonlinear, in other words, amplitude dependent structures. Figure 4, given below, shows the frequency response change when the amplitude changes. The movement of the granular structures in the enclosed cavity strongly depend on the excitation amplitude, according to the finding which has already been discovered but validated once more.

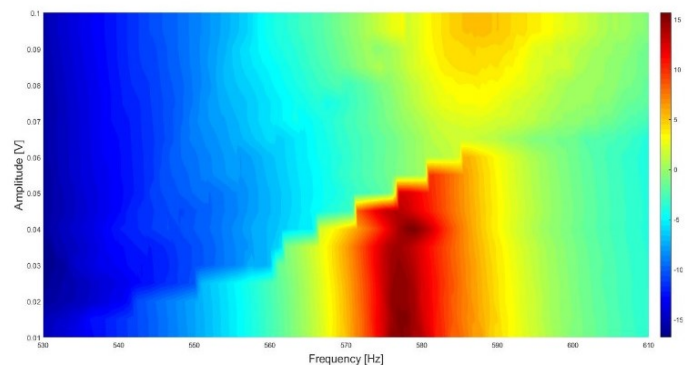

Figure 4: Amplitude dependency of the particle dampers

In comparison between the steel particles attachment and the DELRIN POM particles attachment, the viscoelastic granules have a better absorption property even for a small amount of particles (Figure 5). However, both type of granules has reduced the natural frequency of the main structure.

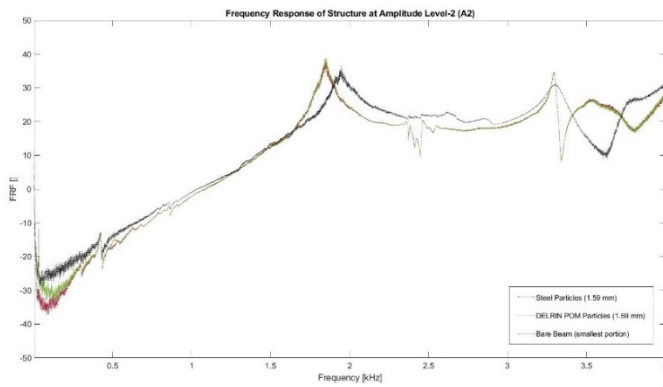

Figure 5: Comparison of metal particles and viscoelastic particles

In addition to the experimental study, unit cell modelling of the particle damper using two different granular materials are given below in Figure 6. According to the figure, bare beam (Figure 6-a) showed the isotropic structure behaviour while experiencing acoustic and optic modes in the same structure. Also, adding a resonating damper to the bare beam unit cell shaped the modes on the structure (Figure 6-b). Moreover, in Figure 6-c and -d, steel particle attachment and DELRIN POM particle attachments are given in the order. According to the figures, metallic particles increased the damping ability of the structures by controlling the dispersion on the main structure. However, this behaviour should be questioned in several ways and variety of criteria.

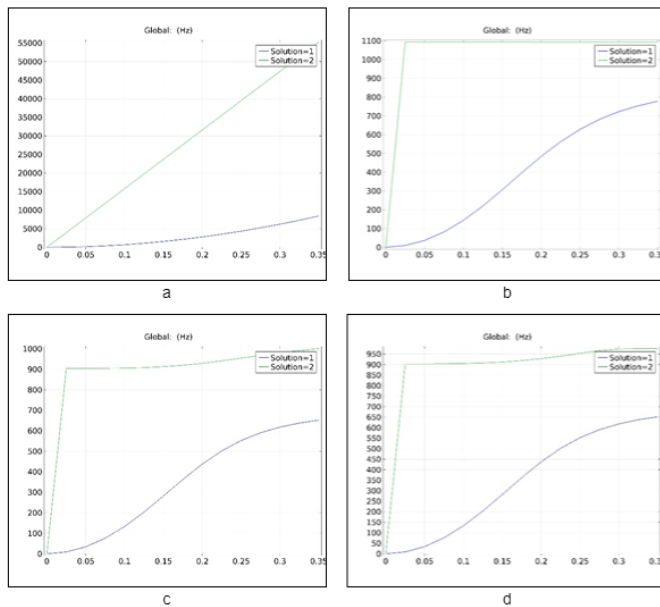

Figure 6: Comparison between the infinite structure models

Conclusion

This is a particle damper-based (nonlinear damper-based) metamaterial modelling included study which is developed as in experimental and numerical research options. According to the metamaterial understanding, locally resonant damper cavity has been modelled and experimentally studied as explained in the methodology section.

Analysed granular structure relationships motivated the equivalent material modelling and these properties have been applied in the resonating damper-particle damper in the

FEM-based numerical studies. Unit cell modelling is prepared using the Bloch-Floquet Theory in the numerical studies.

According to the research methodology which has been followed through the studies, locally resonant damper cavity and additional particle placement in the cavity reduced the excitation impact from the main (base, beam) structure. Unit cell (infinite structure) modelling showed that periodic arrangement of the particle dampers widened the bandgap and increased the nondispersive properties on the main structure. Also, particle material has been questioned through the experimental and the numerical study methods. Equivalent material modelling technique has been used in the research methodology.

As this is primary methodology improvement aimed study, the amount of different materials of granules in the cavity will be questioned. In addition to this, the size of the unit cell will be questioned, as well. In general, the study is quite new application for the nonlinear damping options and is under improvement in the research manner.

References

- [1] Z. Lu, Z. Wang, S. F. Masri, and X. Lu, "Particle impact dampers: Past, present, and future," *Structural Control and Health Monitoring*, vol. 25, no. 1, pp. 1–25, 2018, doi: 10.1002/stc.2058.
- [2] B. Darabi and J. A. Rongong, "Amplitude dependent damping from granular viscoelastics," *Journal of Physics: Conference Series*, vol. 382, no. 1, 2012, doi: 10.1088/1742-6596/382/1/012026.
- [3] G. Sun, "An Investigation of Particle Dampers for Increasing the Dynamic Damping of Spacecraft Pipework Assemblies," no. August, 2020.
- [4] S. G. Demiryurek, A. Krynkina, and J. Rongong, "Non-linear metamaterial structures: Array of particle dampers," *Proceedings of the International Congress on Acoustics*, vol. 2019-Septe, no. September, pp. 4878–4884, 2019, doi: 10.18154/RWTH-CONV-239301.